

**High Productivity Cooking
 Electric Tilting Boiling Pan, 150lt Hygienic
 Profile, Freestanding with Stirrer and
 Variable Speed**

ITEM # _____

MODEL # _____

NAME # _____

SIS # _____

AIA # _____

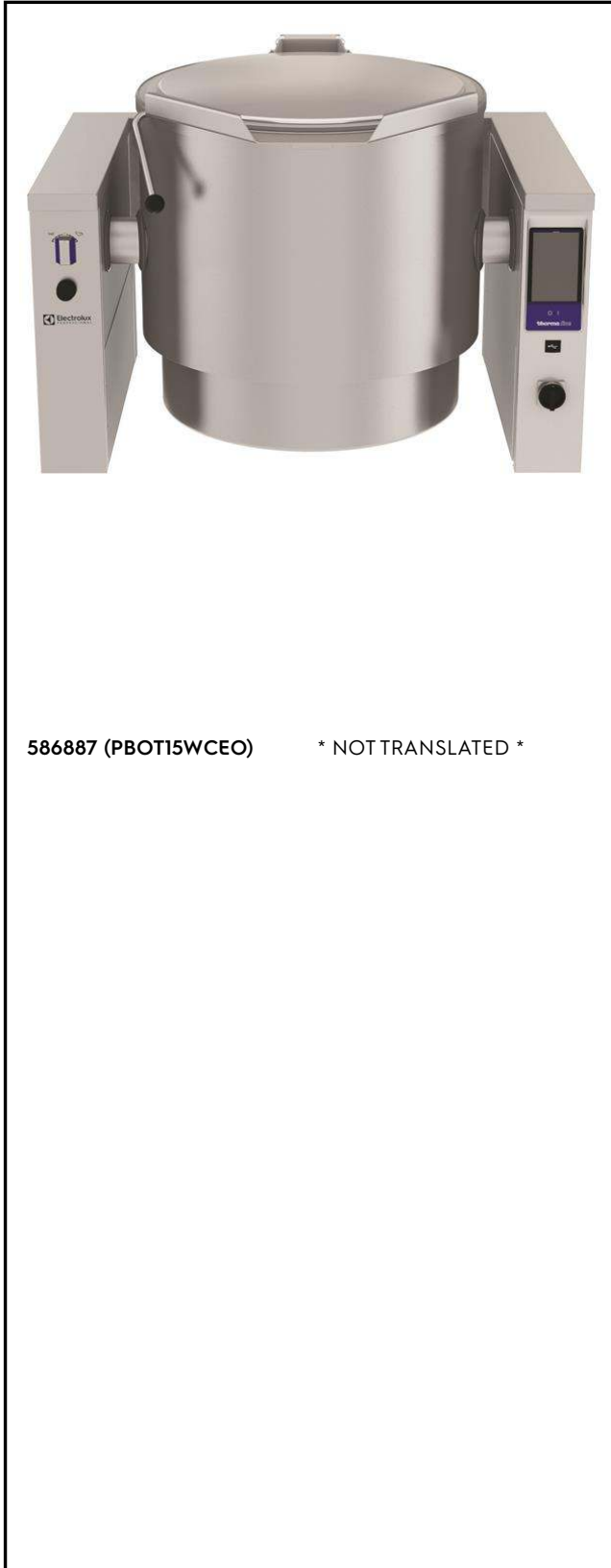

586887 (PBOT15WCEO)

* NOT TRANSLATED *

Main Features

- Kettle is suitable to boil, steam, poach, braise or simmer all kinds of produce.
- Motorized, variable pan tilting with "SOFT STOP". Tilting and pouring speeds can be precisely adjusted. Pan can be tilted over 90° to facilitate pouring and cleaning operations.
- USB connection to easily update the software, upload/download recipes and download HACCP data.
- Mixing stirrer works at variable speed from 10 to 100 rpm with 3 rotation patterns.
- Kettle is jacketed up to 159 mm from upper rim.
- Ergonomic vessel dimensions, with a large diameter and shallow depth facilitates stirring and gentle food handling.
- Isolated upper well rim avoids risk of harm for the user.
- Edge of the large pouring lip can be equipped with a strainer (option).
- Built in temperature sensor to precisely control the cooking process.
- IPX6 water resistant.
- Max pressure of inner jacket at 1.7 bar; minimum working pressure at 1 bar. Allows temperature control between 50 and 110°C.

Construction

- GuideYou Panel - activated by the user via settings - to easily follow the multiphase recipes, granting a proper and controlled cooking and a better appliance optimization. The system will provide maintenance reminders, in line with ESSENTI
- Highly-visible and bright led TOUCH control panel features user-friendly icons and intuitive self-explanatory command options. Display visualizes:
 - Actual and set temperature
 - Set and remaining cooking time CHAR(13)CHAR (
- Water mixing tap is available as optional accessory to make water filling and pan cleaning easier.
- Possibility to store recipes in single or multiphase cooking process, with different temperature settings.
- External panelling and internal frame made of 1.4301 (AISI 304) stainless steel.
- Front-mounted inclined led "TOUCH" control panel with recessed deep drawn casing, features self-explanatory display functions which guide operator throughout the cooking process: simultaneous display of actual and set temperature as well as set cooking ti
- Safety thermostat protects against low water level in the double jacket.
- Minimised presence of narrow gaps for easier cleaning of the sides to meet the highest hygiene standards.
- Ergonomic and user friendly thanks to the high tilting position and the pouring lip design which allow to easily fill containers.

APPROVAL: _____

- 98% recyclable by weight; packaging material free of toxic substances.
- Double-lined insulated lid in 1.4301 (AISI 304) stainless steel mounted on the cross beam of the unit, counterbalanced by a hinge that remains open in all positions.
- Safety valve avoids overpressure of the steam in the double jacket.
- Can be prearranged for energy optimisation or external surveillance systems (optional).
- Cooking vessel in 1.4435 (AISI 316L) stainless steel featuring directional pouring lip. Double-jacket in 1.4404 (AISI 316L) stainless steel designed to operate at a pressure of 1.5 bar.

User Interface & Data Management

- Connectivity ready for real time access to connected appliances from remote and data monitoring (requires optional accessory - contact the Company for more details).

Included Accessories

- 1 of Emergency stop button - factory fitted PNC 912784
- 1 of - NOT TRANSLATED - PNC 913543

Optional Accessories

- Strainer for 150lt tilting boiling pans PNC 910004
- Measuring rod for 150lt tilting boiling pans PNC 910045
- Grid stirrer for 150lt boiling pans PNC 910064
- Grid stirrer and scraper for 150lt boiling pans PNC 910094
- Strainer rod for stationary round boiling pans PNC 910162
- Stainless steel plinth for tilting units - against wall - factory fitted PNC 911425
- Stainless steel plinth for tilting units - freestanding - factory fitted PNC 911455
- Bottom plate with 2 feet, 200mm (height 700mm) PNC 911930
- Food tap strainer for tilting boiling pans PNC 911966
- C-board (length 1300mm) for tilting units - factory fitted PNC 912185
- POWER SOCKET CEE-16A / 380V BUILT-IN PNC 912468
- POWER SOCKET CEE-32A / 380V BUILT-IN PNC 912469
- Power socket Schuko typ-23, 16A/230V, built-in version PNC 912470
- Power socket Swiss typ-23, 16A/230V, built-in version PNC 912471
- Power socket Swiss typ-23, 16A/380V, built-in version PNC 912472
- Power Socket, SCHUKO, built-in, 16A/230V, IP55, black - factory fitted PNC 912473
- Power Socket, CEE16, built-in, 16A/230V, IP67, blue-white - factory fitted PNC 912474
- Power Socket, TYP23, built-in, 16A/230V, IP54, blue - factory fitted PNC 912475
- Power Socket, SCHUKO, built-in, 16A/230V, IP54, blue - factory fitted PNC 912476

- Power Socket, TYP25, built-in, 16A/400V, IP54, red-white - factory fitted PNC 912477
- Panelling for plinth recess (depth from 70 to 270mm) for tilting units - factory fitted (Deutschland, Austria, Switzerland) - factory fitted PNC 912479
- Additional panelling plinth for tilting units (width 120mm) - factory fitted (Deutschland, Austria, Switzerland) PNC 912486
- Manometer for tilting boiling pans - factory fitted PNC 912490
- Connecting rail kit for appliances with backsplash, 900mm PNC 912499
- Connecting rail kit, 900mm PNC 912502
- Rear closing kit for tilting units - against wall - factory fitted PNC 912705
- Automatic water filling (hot and cold) for tilting units - to be ordered with water mixer - factory fitted PNC 912735
- Kit energy optimization and potential free contact - factory fitted PNC 912737
- Rear closing kit for tilting units - island type - factory fitted PNC 912745
- Lower rear backpanel for tilting units, island type PNC 912769
- Mainswitch 60A, 10mm² - factory fitted PNC 912774
- Spray gun for tilting units - freestanding (height 700mm) - factory fitted PNC 912776
- Food tap 2" for tilting boiling pans (PBOT) - factory fitted PNC 912779
- Connecting rail kit, right PNC 912975
- Connecting rail kit, left PNC 912976
- Connecting rail kit for appliances with backsplash, right PNC 912981
- Connecting rail kit for appliances with backsplash, left PNC 912982
- - NOT TRANSLATED - PNC 913554
- - NOT TRANSLATED - PNC 913555
- - NOT TRANSLATED - PNC 913556
- - NOT TRANSLATED - PNC 913557
- - NOT TRANSLATED - PNC 913567
- - NOT TRANSLATED - PNC 913568
- - NOT TRANSLATED - PNC 913578

Front

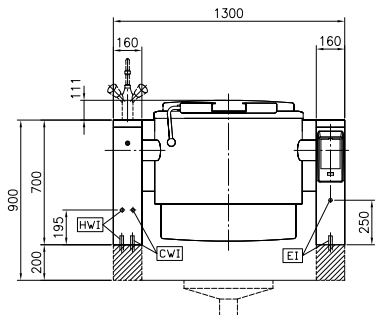

Side

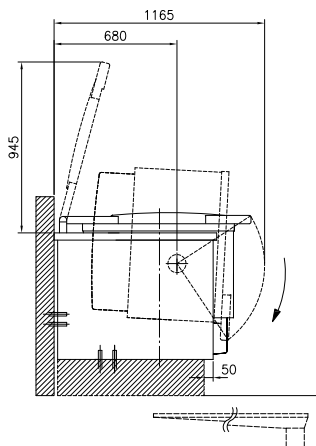

CWI = Cold Water inlet 1 (cleaning)
 EI = Electrical inlet (power)
 HWI = Hot water inlet

Top

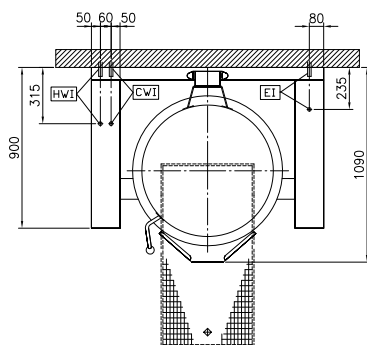

Electric

Supply voltage: 400 V/3N ph/50/60 Hz
 Total Watts: 28 kW

Installation:

Type of installation: FS on concrete base; FS on feet; On base; Standing against wall

Key Information:

Working Temperature MIN: 50 °C
 Working Temperature MAX: 110 °C
 Vessel (round) diameter: 710 mm
 Vessel (round) depth: 465 mm
 External dimensions, Width: 1300 mm
 External dimensions, Depth: 900 mm
 External dimensions, Height: 700 mm
 Net weight: 290 kg
 Configuration: Round, tilting, with stirrer
 Net vessel useful capacity: 150 lt
 Tilting mechanism: Automatic
 Double jacketed lid: ✓
 Heating type: Indirect

Energy Consumption

Standard: DIN18855-1: 2005-07
 Item heated: 150 lt Water
 Heat up temperature: From 20°C to 90°C
 Heat up time: 32.6 min

Sustainability

Energy consumed in heat up phase: 12.91 kWh
 Energy efficiency: 94.58 %